

Representation of the outer dimensions (See the details in visualization)

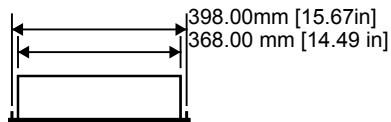
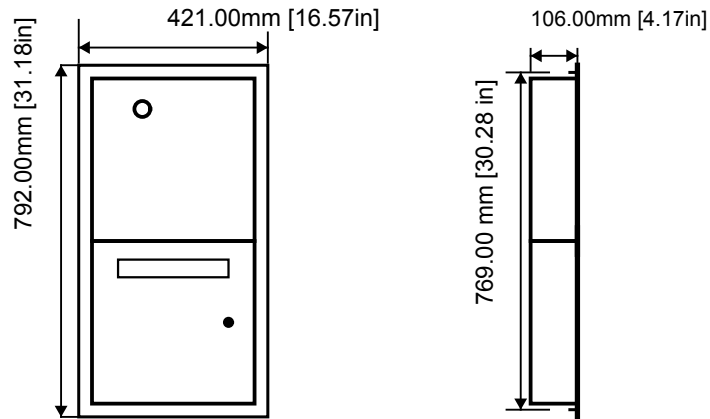

Installation Dimensions (W x H x D) = 398.00 mm [15.67 in] x 769.00 mm [30.28 in] x 106.00 mm [4.17 in]

This configuration weighs around 17 KG.

Technical data:

1 x Nameplate configuration DBI-73374378
1 x flush-mounted letterbox with covers
Letterbox flap with nameplate, white, for self-labeling, not illuminated. Flush with front panel.

Stainless steel V4A (salt-water resistant), brushedManufacturing according to general manufacturing tolerances per DIN ISO 2768-cK, unless otherwise specified.

Gap between modules and frame segments: 1.5 mm (0.06 inches), gap between modules: 3 mm (0.12 inches).

This system is an individual production according to customer specifications. The legal right of withdrawal therefore does not exist according to § 312 g Abs. 2 Nr. 1 BGB. Since the automated production process is started immediately after receipt of the order, a cancellation, a return or exchange after placing the order is not possible.

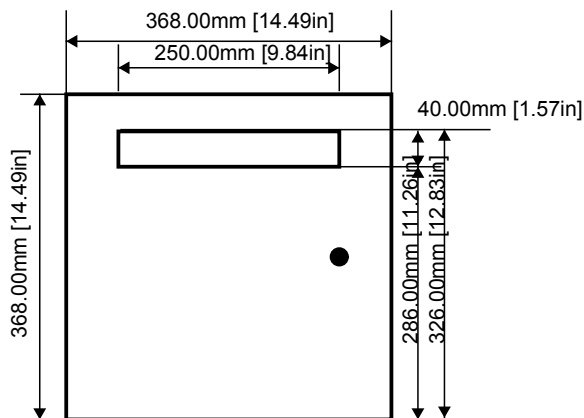

Date: 2026-05-26
Time: 23:57:45 CET
Project ID: DBL-79529886



Bird Home Automation GmbH
Uhlandstraße 165
D-10719 Berlin, Germany
Confidential